

EXNER PROCESS EQUIPMENT

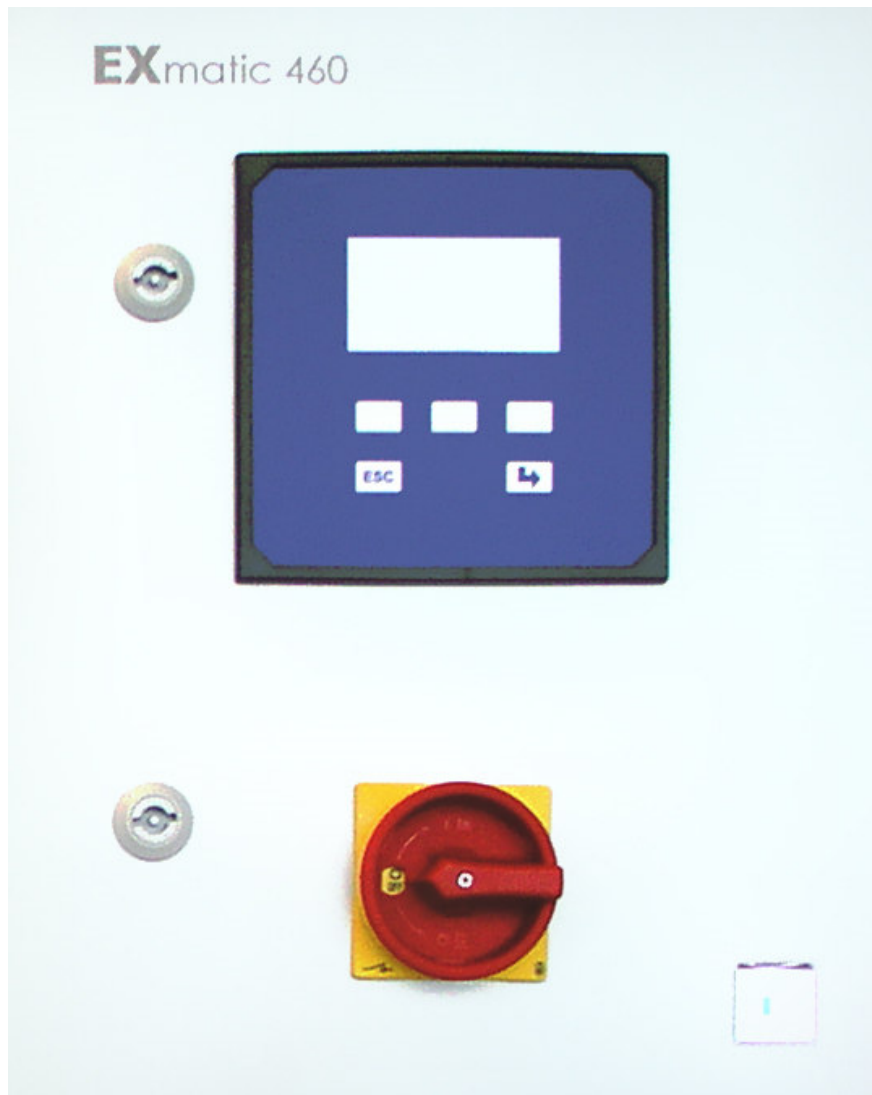

EXMATIC 460

Control unit
Technical information

All brand and product names are trademarks of the company
EXNER PROCESS EQUIPMENT GmbH

Imprint

Editor:

EXNER PROCESS EQUIPMENT GMBH
Carl-Metz-Str. 26
76275 Ettlingen
Germany

Date of issue: 2019-02-11

© 2007, Dipl.-Ing. Detlef Exner

As of 07.02.2019

File: EXmatic 460 TI eng 190207

All rights, including the rights in the translation, are reserved.

The content of these operating instructions may only be reproduced with the written consent of EXNER PROCESS EQUIPMENT GMBH, ETTLINGEN, Germany.

All technical information, drawings etc. are subject to the copyright law.

Subject to technical modifications.

This document was printed on chlorine and acid-free paper.

Table of contents

1	Product description	3
1.1	Control unit EXMATIC 460	3
1.2	Process integration	4
2	Program functions	7
2.1	Automatic start of cleaning	7
2.2	Seal water	8
2.3	Cleaning program	8
3	Assembly	11
3.1	Wall mounting	11
3.2	Electric connections	12
3.3	Pneumatic connections	13
3.4	Rinse valve connections	14
4	Technical data	15
4.1	Standards	15
4.2	Material	15
4.3	Connected loads	15
4.4	Ambient conditions	16
4.5	Pneumatics	16
4.6	Rinse valves (option)	16
4.7	Dimensions	17
4.8	Order structure EXmatic 460	17
5	Spare parts and accessories	19

1 Product description

1.1 Control unit EXMATIC 460

View from outside

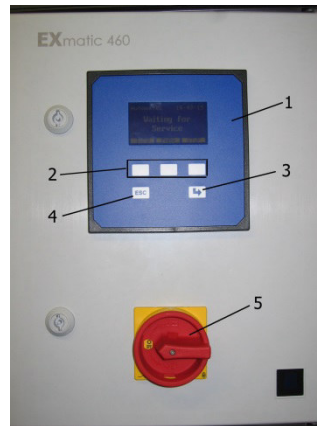

- 1 Operating panel
- 2 Function keys
- 3 Return button
- 4 ESC button
- 5 Main switch

Figure 1: Control unit outside

View from inside

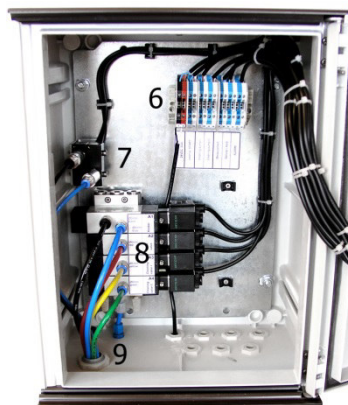

- 6 Terminal board
- 7 Indicator/pressure switch
- 8 Pilot valve
- 9 Input multi hose

Figure 2: Control unit inside

Function The control unit EXMATIC 460 can fully automatically control and monitor the measuring and cleaning cycles of a pneumatic interchangeable fitting. For doing this, the cleaning times, measuring intervals and the starting times can be parameterized and adjusted to the respective specification.

Input The control monitors the respective position indication of the interchangeable fitting via integrated inputs.

Automatic cleaning can be started via an enlarged input.

Output The respective condition of the interchangeable fitting and of the control can be transmitted to a higher process control system via three contact outputs.

Interchangeable fitting The interchangeable fitting and the cleaning valves for controlling the cleaning solutions are connected to the control unit by means of pneumatic hoses. This should be done with the adjusted EXconnect multi hose.

1.2 Process integration

The control unit EXMATIC 460 is supplied with 24V DC and with compressed air 4-6 bar. The connection of the interchangeable fitting and the cleaning and drain valves is realized by pneumatic hoses which are gathered in a multi hose.

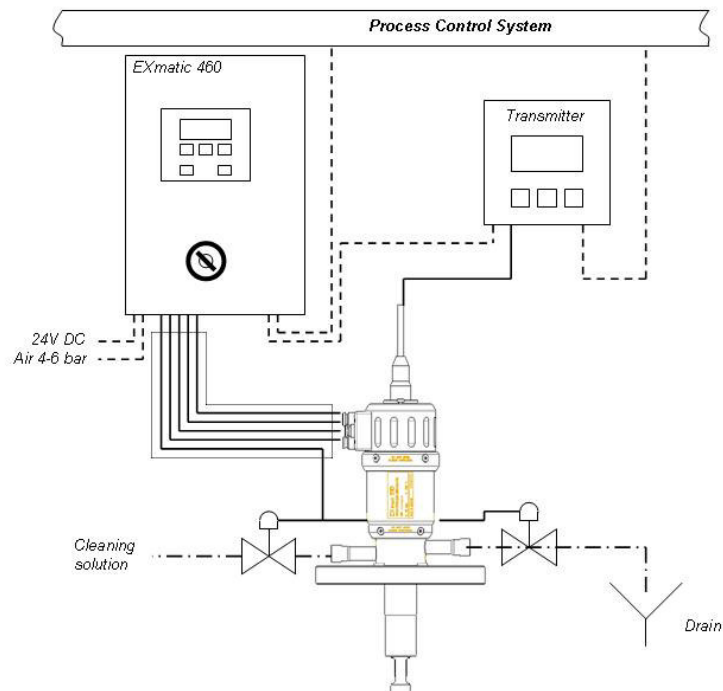

Figure 3: Process sequence

The respective status of the measuring unit (alarm status, measuring status, cleaning status) can be transmitted to a higher process control system by means of contacts.

A cleaning cycle can be started via an external trigger, e.g. from the pH transmitter.

The control unit EXmatic 460 is a completely independent control unit and can principally be operated without any connection to a transmitter or a process control system.

The control unit has a manual as well as an automatic mode. The manual mode is for manually triggering the movement of the interchangeable fitting and the individual cleaning valves.

In automatic mode, a parameterized cleaning process is run after starting a cleaning cycle. After completion, the interchangeable fitting moves to the measurement position.

2 Program functions

2.1 Automatic start of cleaning

In principal, there are 3 different ways of starting an automatic cleaning cycle. They can also be combined in a useful manner.

Loop A recurring cycle is run via the internal clock (loop). In doing so, after a parameterized measuring time, cleaning is started automatically, e.g. every four hours. After completion of the cleaning process, the interchangeable fitting moves to the measurement position and the cycle runs again.

Real Time Event Automatic cleaning is started at a specific point in time which can be parametrized (Real Time Even), e.g. every day at 8.15 a.m., 12 noon and 4.30 p.m.. After completion of the cleaning process, the interchangeable fitting moves to the measurement position and stays there until the next Real Time Event starts.

External Trigger Cleaning is started via an external trigger. After completion of the cleaning and after opening the external trigger, the interchangeable fitting moves to the measurement position and stays there until the external trigger is closed again.

Loop + Trigger As described, cleaning is carried out in a defined cycle (loop). Further cleaning processes can additionally be started via an external trigger and the interchangeable fitting can be kept in the cleaning position. This function is used if the sensor is to be watered during operating lives and if the defined cycle is to be interrupted, or if the sensor is to be pulled back into the rinsing chamber for being protected while a strong agitator is running in the container.

Event + Trigger As described, cleaning is carried out at defined points in time (Real Time Event). In addition, further cleaning processes can be started via an external trigger and the interchangeable fitting can be kept in the cleaning position. This function is used if the sensor is to be watered during operating lives and if the cycle is to be interrupted. Or if the sensor is to be pulled back into the rinsing

chamber for being protected while a strong agitator is running in the container.

2.2 Seal water

For the short time during which the measuring window moves over the sealing elements, when the interchangeable fitting moves from the measurement position to the cleaning position or back, there is a connection between the measuring material and the rinsing chamber. To ensure that as little measuring material as possible can access the rinsing chamber and that the sealing elements are additionally rinsed during this time, a seal water function can be parameterized.

Function If the seal water function is active, the "Cleaning I" valve always opens before the interchangeable fitting is moved. This means that if the water pressure connected to the "Cleaning I" valve is higher than the process pressure, the water (seal water) runs through the rinsing chamber to the process during the movement of the interchangeable fitting and thus prevents measuring material from accessing the rinsing chamber. The sealing elements of the rinsing chamber are rinsed at the same time.

The seal water function ensures a better cleaning of the sensor, maintenance of the sealing elements and increases the operating life of the sensor and of the sealings. The function should always be active, if possible.

If you do not want seal water running to the measuring material or if this is not admitted, the seal water function can also be deactivated. The general function of the interchangeable fitting and the control is not impaired by that.

2.3 Cleaning program

As soon as a cleaning program is started (see 3.1), the following functions are run one after the other:

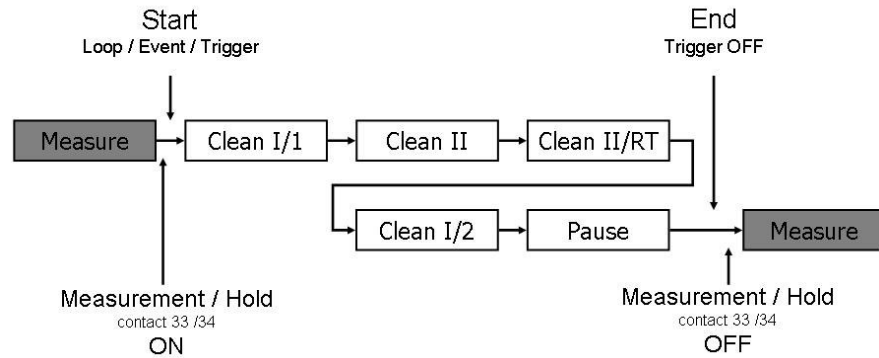

Figure 4: Program sequence

Cleaning I/1 Cleaning with 1. cleaning solution, e.g. water.

„Cleaning I“ valve and drain valve are opened and close again after the preset time (10...300 seconds).

By opening the „Cleaning I“ valve, a delivery pump can be triggered via an outlet trigger (no. 21 + 22).

Cleaning II Cleaning with 2. cleaning solution, e.g. acid.

„Cleaning II“ valve and drain valve are opened and close again after the preset time (0...300 seconds). If this time is set to "0", this program step is let out completely.

By opening the "Cleaning II" valve, a delivery pump can be triggered via an outlet trigger (no. 23 + 24).

Cleaning II RT Exposure time for 2. cleaning solution

Cleaning II RT is a reaction time for the 2. cleaning solution and provided so that the cleaning acid, which was put into the rinsing chamber, is able to react, for example.

All cleaning valves and the drain valve stay closed. After the preset time (0...300 seconds), the next program step follows. If this time is set to "0", this program step is left out completely.

Cleaning I/2 Cleaning with 1. cleaning solution, e.g. water.

"Cleaning I" valve and drain valve are opened and close again after the preset time (0...300 seconds). If this time is set to "0", this program step is left out completely.

By opening the "Cleaning I" valve, a delivery pump can be triggered via an outlet trigger (no. 21 + 22).

Pause If the sensor is **not** to be moved again into the process directly after cleaning, the pause time is activated.

This is particularly recommended if the measuring medium is especially aggressive and therefore the lifetime of the sensor is especially short. In this case, short measuring intervals and long pause times can minimize the dipping time of the sensor and thus increase the lifetime.

The sensor remains in the rinsing chamber, all cleaning valves and the drain valve remain closed. After the preset time (0...999 minutes), the sensor moves to the measurement position. If the time is set to "0", this program step is left out completely.

Measure Measuring interval at parameterization "loop" or "loop + trigger".

The sensor is moved to the measurement position and stays there for the preset time (1...999 minutes). This time can be interrupted in case of parameterization "loop + trigger" by an external trigger. After this time has lapsed, the next cleaning cycle begins.

3 Assembly

3.1 Wall mounting



Ensure that

- there is enough working space for operating the control unit.
- possible voltage-supplying units are disconnected from the mains.
- you only use approved tools.

Mount the control cabinet as shown below:

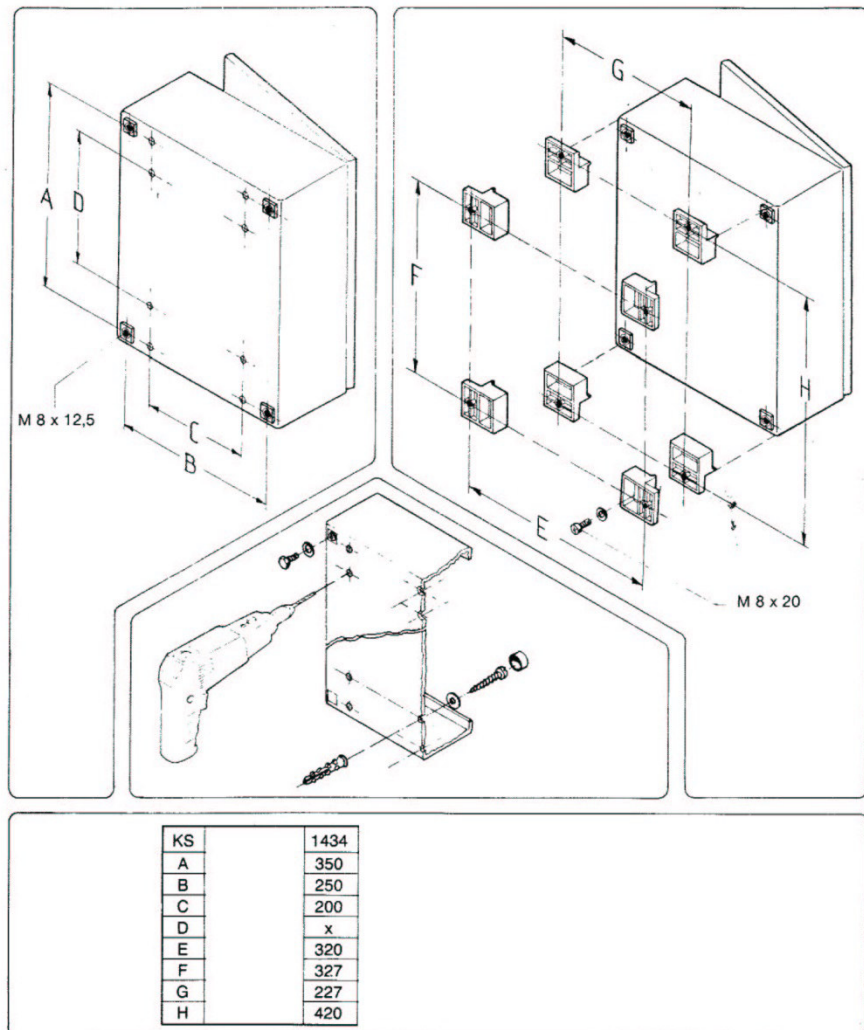

Figure 6: Wall mounting

3.2 Electric connections



The control unit must be disconnected from the mains and the compressed air must be pressureless!

DANGER!



There is the risk for life and limb if the voltage supply is not disconnected!

Connect the control unit according to the circuit diagram:

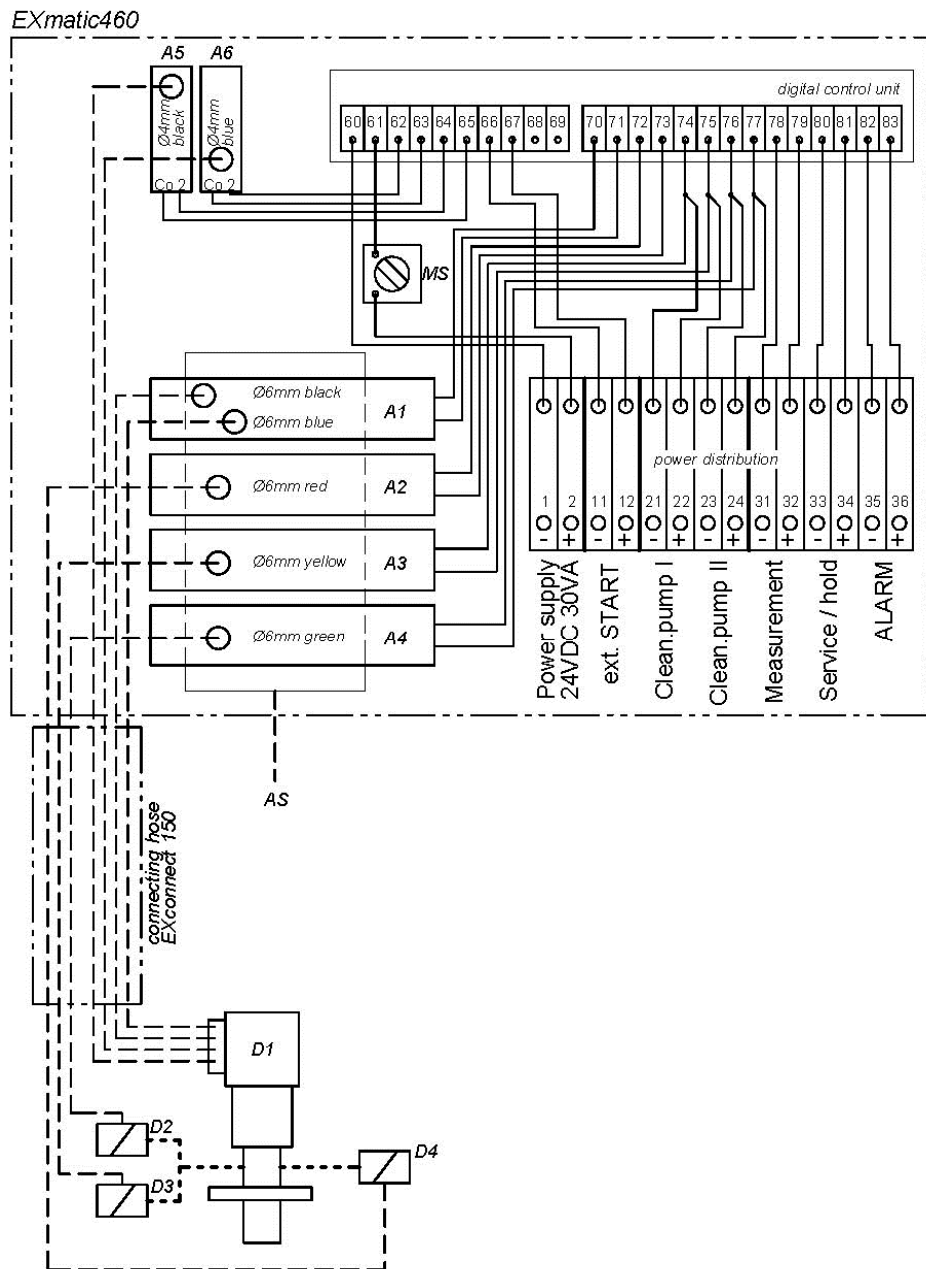

Figure 7: Connection diagram

Pin allocation:

Contact	Description
1	Main Power supply 24VDC 30VA -
2	Main Power supply 24VDC 30VA +
11	Input Start signal (24VDC - selfpowered)
12	Input Start signal (24VDC + selfpowered)
21	Output 24VDC - max.80mA Clean Pump I
22	Output 24VDC + max.80mA Clean Pump I
23	Output 24VDC - max.80mA Clean Pump II
24	Output 24VDC + max.80mA Clean Pump II
31	Output 24VDC - max.100mA measurement
32	Output 24VDC + max.100mA measurement
33	Output 24VDC - max.100mA service / Hold
34	Output 24VDC + max.100mA service / Hold
35	Output 24VDC - max.100mA Alarm
36	Output 24VDC + max.100mA Alarm

3.3 Pneumatic connections

Multi hose			
Control connection	Hose dim./colour	EXtract connection	Note
A1 black	6mm black	1	maintenance
A1 blue	6mm blue	2	measurement
A2	6mm red	D4	drain valve
A3	6mm yellow	D2	Cleaning I
A4	6mm green	D3	Cleaning II
A5	4mm black	3	indicator measurement
A6	4mm blue	4	indicator maintenance

Supply		
Control connection	Hose Dimension	Note
AS	4/6mm	Filtered air 40µm, water and oil-free 4-6 bar

3.4 Rinse valve connections

Rinse valves (option)		
Connection	Dimension	Designation
Compressed air	4/6mm	A
Input rinse medium	Threaded hose connection 4/6 mm or 3/8"	B
Output rinse medium	Threaded hose connection 4/6mm or thread 3/8"	C

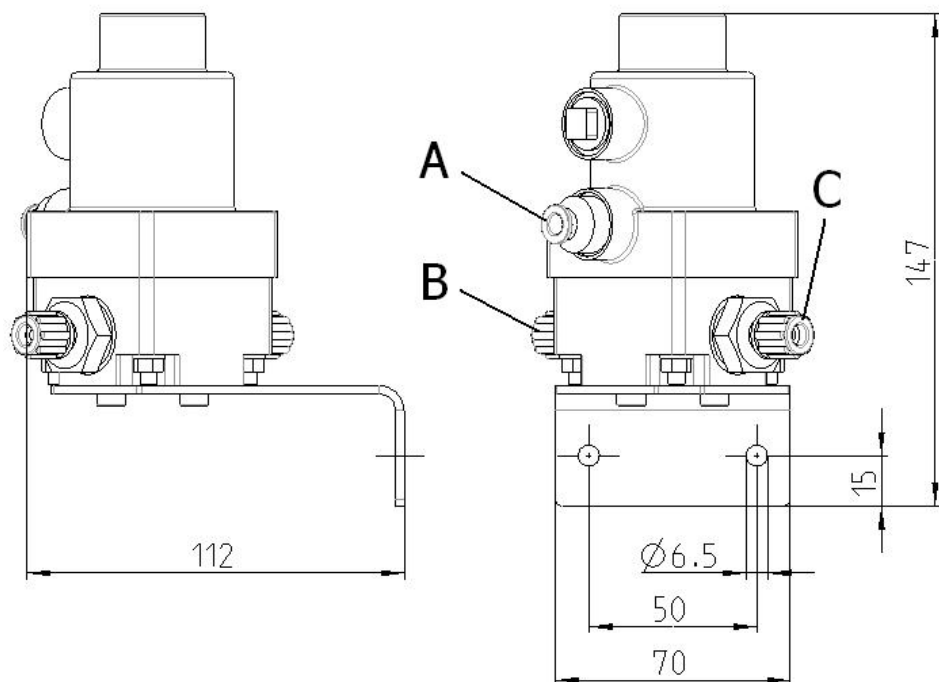

4 Technical data

4.1 Standards

Noise immune according to the standard EN 61000-6-2

Noise-suppressed according to the standard EN 61000-6-4

4.2 Material

Materials			
Control cabinet			
Casing	glass-reinforced plastic		
	stainless steel	option	
Control unit	glass-reinforced plastic	casing	
	plexiglass	protection cover	

4.3 Connected loads

Connected loads		
Voltage supply	24V DC	30 VA
Input for external trigger	24V DC	internal power supply for potential-free contact
Current consumption	0,65 A	
Output for external relais, Cleaning Pump I and Cleaning Pump II	24V DC	80mA max.
Output for status and alarm contacts	24V DC	100mA max.
Triggering pneumatic valves	24V DC	80mA max.

4.4 Ambient conditions

Temperature	
Ambient temperature	0...+55°C
Transport and storage temperature	-10...+60°C

Ambient	
Relative humidity	10...95 % not condensing

Type of protection	
Casing	IP 54
Control unit with safety guard	IP 54 with the safety guard closed

4.5 Pneumatics

Pneumatic hoses		
	outer Ø	inner Ø
for control air	6 mm	4 mm
for position indication	4 mm	2 mm

Compressed air	
	<ul style="list-style-type: none"> - acc. ISO8573-1:2010 [5:4:4] - filtered 40µm, water and oil-free - 4 - 6 bar - no permanent air consumption!

4.6 Rinse valves (option)

Connections		
	outer Ø	inner Ø
Compressed air	6 mm	4 mm
Rinse medium	6 mm	4 mm

4.7 Dimensions

Dimensions		
	Plastic	Stainless steel
Width	300 mm	300 mm
Height	400 mm	400 mm
Depth	250 mm	250 mm

4.8 Order structure EXmatic 460

EXMATIC 460						
	Design.	Casing				
	GF	Plastic glass-reinforce plastic				
	SS	Stainless steel				
	XX	Special version				
		Design.	Cleaning			
		1	for one cleaning solution			
		2	for two cleaning solutions			
		X	Special version			
			Design.	Drain valve		
			0	Without drain valve		
			1	With drain valve		
			Design.	Multi hose		
			00	Without multi hose		
			03	With 3m multi hose		
			05	With 5m multi hose		
			10	With 10m multi hose		
		XX	Special version			
			Design.	Mounting angle		
			00	Without mounting angle		
			EX	EXtract mounting angle		
			RE	Retractex mounting angle		
			XX	Special version		
EXMATIC 460	-	-	-	-	-	Order number

5 Spare parts and accessories

Spare parts		
CONTROL	Spare part	Order number
EXmatic 460	Control unit	9-110-00-002
	Solenoid valve 5/2-way G 1/4" 24VDC 3,8W (without plug and cable)	9-091-10-001
	Solenoid valve 3/2-way G 1/4" 24VDC 3,8W (without plug and cable)	9-091-10-002
	Plug with cable for solenoid valve	7-098-20-001
	Pressure switch (indication)	9-096-00-001

Accessories		
CONTROL CABINET	Accessory	Order number
	wall mounting plastic cabinet	2-083-70-001
	wall mounting stainless steel cabinet	2-083-70-002
	pipe mounting cabinet (plastic/stainless steel)	2-083-70-003
CLEANING VALVES	Accessory	Order number
Membrane valve PVDF/FPM G 3/8", DN12 PN6, pneumatic, pressureless closed (NC)	1 valve for cleaning solution or drainage	2-095-70-001
	2 valves for cleaning solution and drainage, mounted to mounting angles with all connections and PTFE hose	2-095-70-002
	3 valves for two cleaning solutions and drainage, mounted to mounting angles with all connections and PTFE hose	2-095-70-003

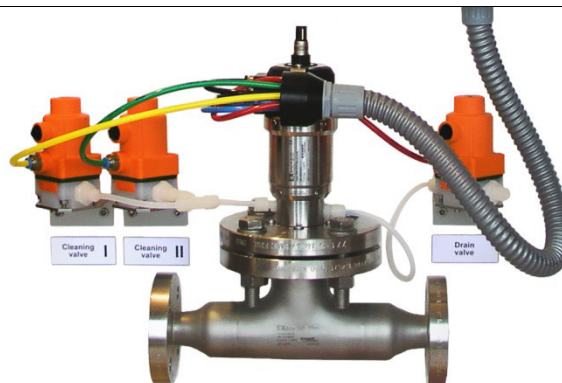

Figure 8: Membrane valves as accessories for the interchangeable fitting



Please indicate the serial number of your fitting if you order spare parts or accessories.

Exner Process Equipment GmbH
Carl-Metz-Str. 26
D-76275 Ettlingen

Fon.: +49 (0)7243 9454290
Fax.: +49 (0)7243 94542999
www.e-p-e.com